

Data Info Sheet part no. 582108 - MB battery backup / charger

Product overview

The Gallagher battery back-up charger provides an automatic battery supply when there is no mains supply to the energizer. The product provides ultimate security for businesses where power to the fence is crucial, such as zoos for example.

The back-up is easy to install and compatible with all I Series and MB/MBS energisers.

The device provides battery power back up in the event of mains power failure and is an important component where 24/7 fence operation is critical (i.e. zoos).

The product is fully encapsulated in an aluminium box for maximum heat dissipation and protection against moisture.

The battery backup charger is quick and easy to install and provides peace of mind for farmers that experience power outages but cannot avoid their fence system to stop performing.

Key benefits

Easy to install – the device is compatible with MB iSeries and MB/MBS energizers and only requires 3 points of connection.

LED indication – The two LEDs on the battery back-up charger indicate whether the energizer system is running of mains or battery.

Gallagher Reliability: Extensive testing and industry leading manufacturing processes provide exceptional reliability under harsh farm conditions.

Product Features

Connection



When connected to the system, both mains and battery LED will be illuminated green indicating both power sources are connected. In the event of mains failure, the mains LED will turn off and only the battery LED will remain on indicating the system is operating on battery.

Diagram

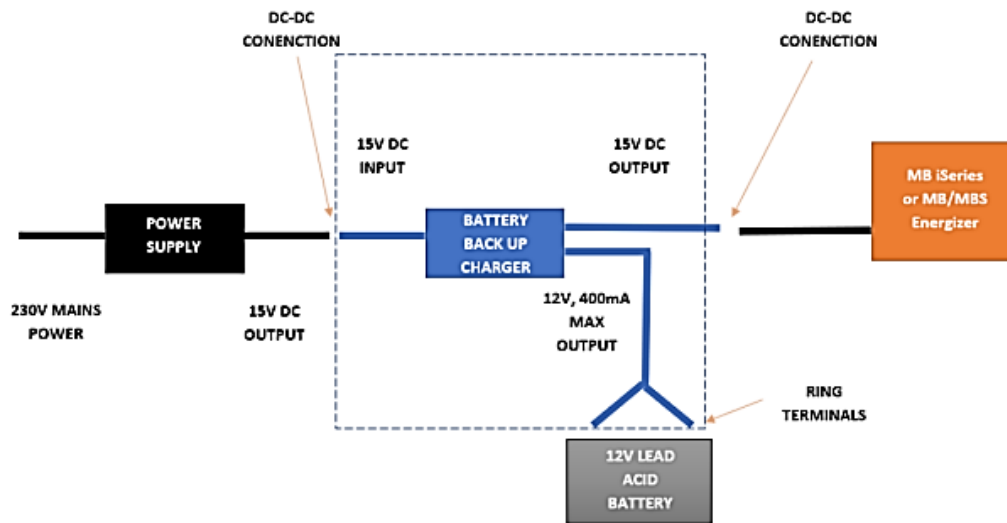

Product Details

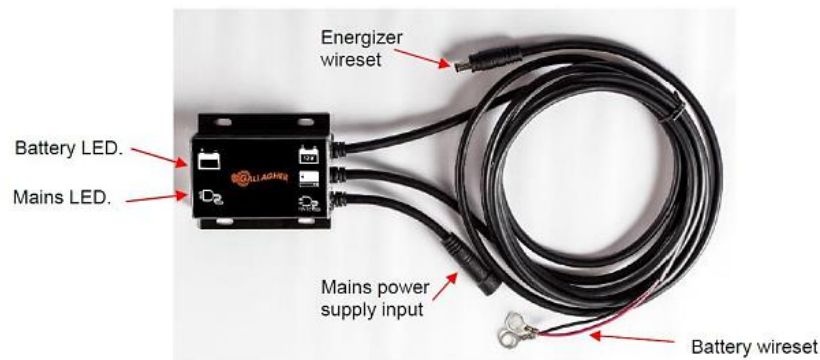

Product Description:	MB battery backup charger
Maximum Output current:	400mA
DC Input:	15V DC
GE Part Number:	582108
Barcode (EAN):	9414701582108
Weight (kg):	0.4kg
Packaging dimensions:	55x200x210mm
Shipper Quantity:	1 pc.
Warranty Period:	2 Years

Content box

- 1x 12V Battery Back-up unit
- 1x 230V Power Supply
- 1x Manual
- 1x Battery clips (plus en min)
- 1x Power cord EU (type C, E & F)
- 1x Power cord UK (type G)
- 1x Power cord USA (type A)